

Model ECS35 - ESS35B52

5" - 14 gauge spun aluminum ball
gold anodized

Single sheave truck, cast aluminum
revolving, non-fouling type

2 Bronze swivel snaps with covers
per halyard

1 Set of halyard: #10 poly

1 - 9" Cast aluminum cleat

Aluminum flash collar

3000 PSI concrete

Hardwood wedges
(supplied by others)

Dry sand tightly tamped
after aligning pole

Foundation sleeve -16 ga
hot dip galvanized steel

Steel centering wedges

1/4" Steel base plate

1/4" Steel support plate
welded to grounding spike

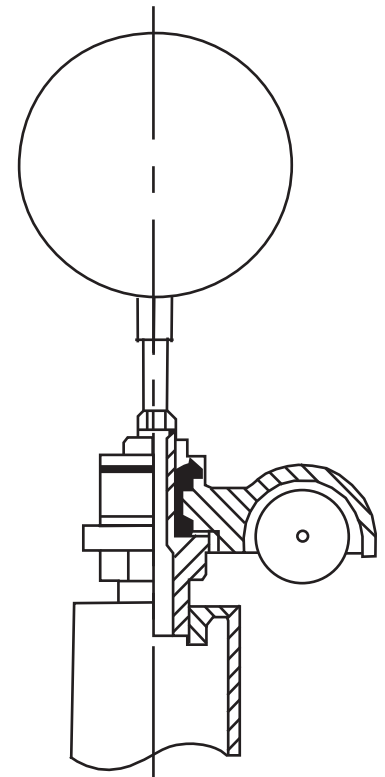

Truck Detail

Aluminum body
Stainless steel ball bearings
Aluminum sheave
Cast aluminum spindle

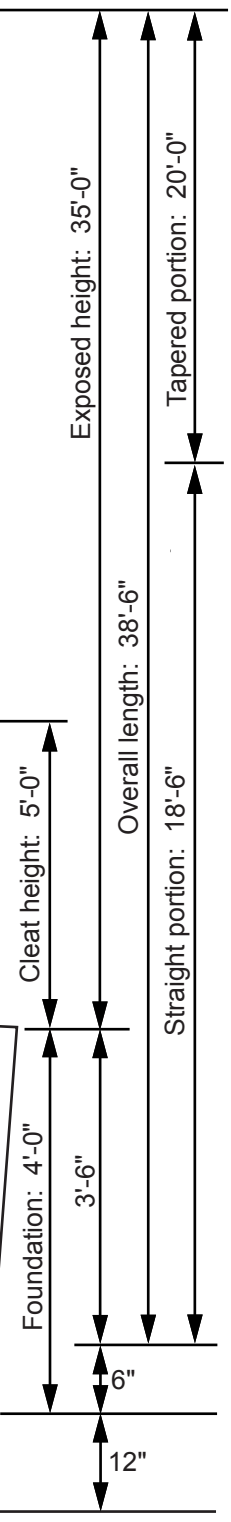

All shafts with overall
length of more than
38'-6" are shipped in
two sections.

Each section matched
marked for field assembly.
Exposed portion of jam
sleeve must be **well
lubricated** prior to
assembly.

1-1/2" maximum shop
gap allowed for field
fitting (ram for tight joint)

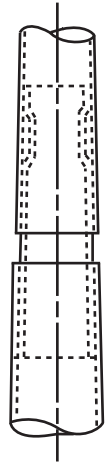

Project:	Ground set tapered aluminum flagpole: ALLOY: 6063T6	FLAGPOLES ETC.	Date:
Location:	Exposed height: 35'-0"	Overall height: 38'-6"	407 Hadley St.
Architect:	Ship in 2 sections	Butt diameter: 5"	Holly, MI 48442
Contractor:	Top diameter: 3"	Wall thickness: .125"	(888) 735-5591
Customer:	Finish: 100 grit polish		Job: